

# a120nx

Horizontal Machining Center

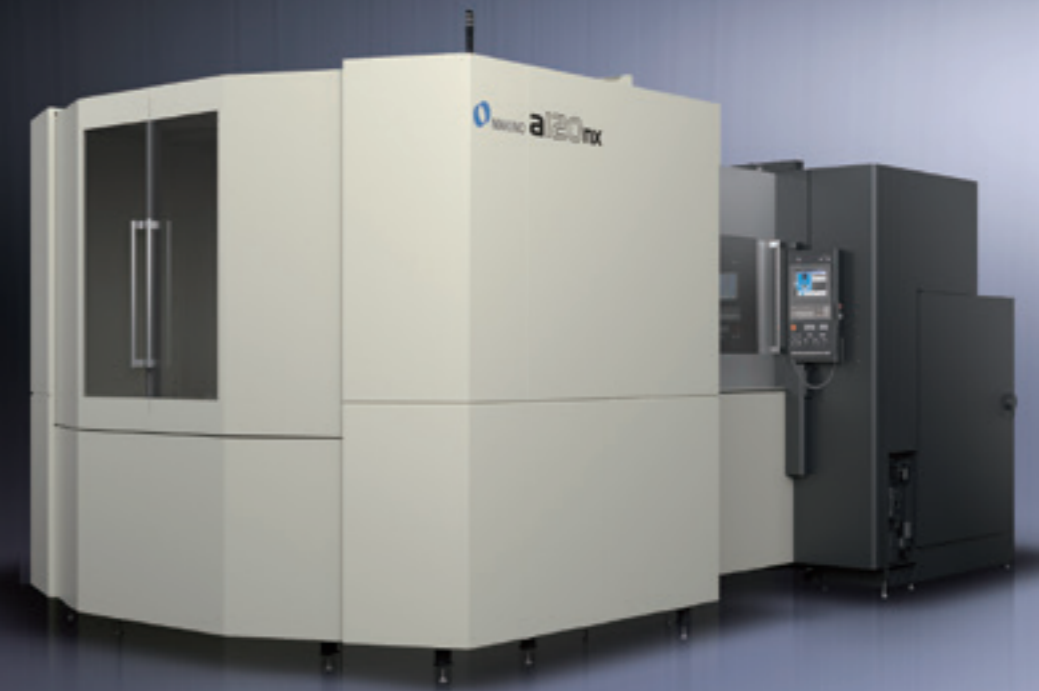

[www.makino.co.jp](http://www.makino.co.jp)



Atsugi and Fuji Katsuyama works are certified for ISO14001 and ISO9001.

\*The specifications, figures, and overviews of products, peripheral devices and accessories in this catalogue may be changed without prior notice to incorporate improvements resulting from ongoing R&D programs.  
\*The all products in this catalogue include the optional specifications and equipment.  
\*The products, including technical data and software, may be subject to the Foreign Exchange and Foreign Trade Control Law in Japan.  
Prior to any re-sale, re-transfer or re-export, please contact Makino to obtain any required authorization and approval.

M468Ea 2002/1 (V-T-F)



*A high-speed machine of the 1000 mm × 1000 mm pallet  
that pursued reliability and productivity*

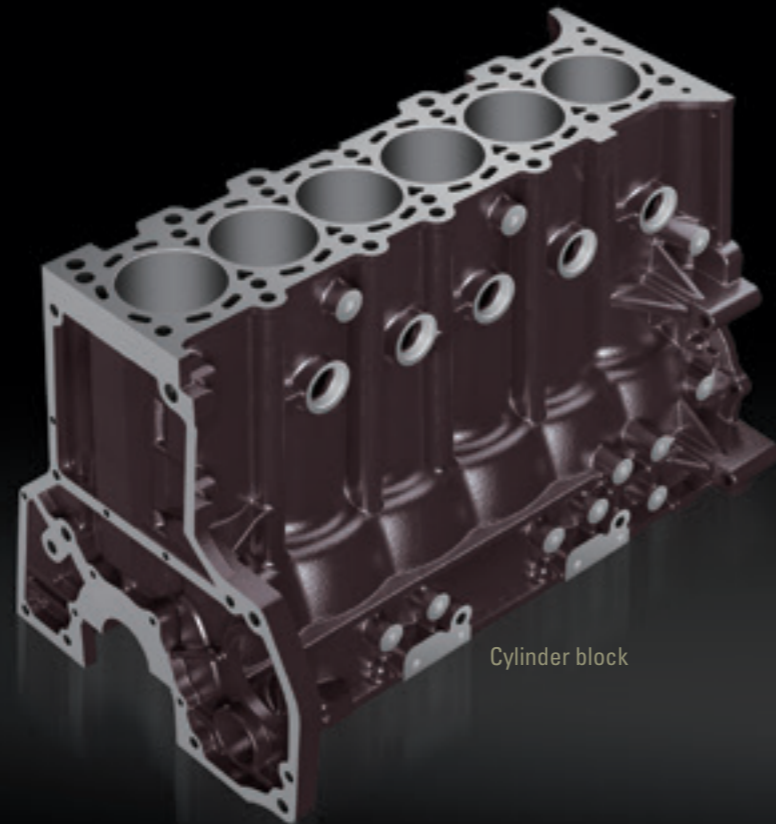

Cylinder block

Most suitable for structural parts machining for large industrial machine such as Automobiles, energy, construction machines, agricultural machines and semiconductor manufacturing equipment etc.

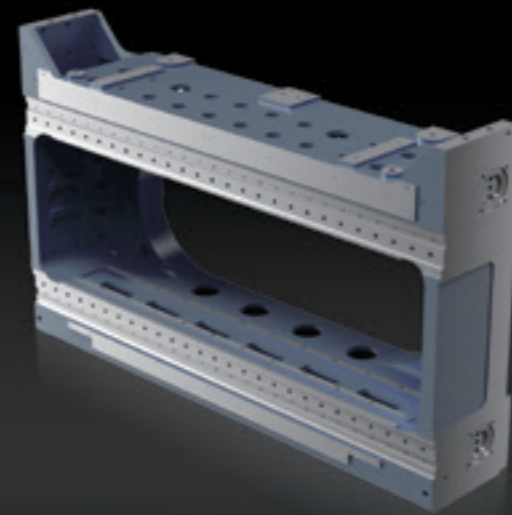

Structural parts for large industrial machine

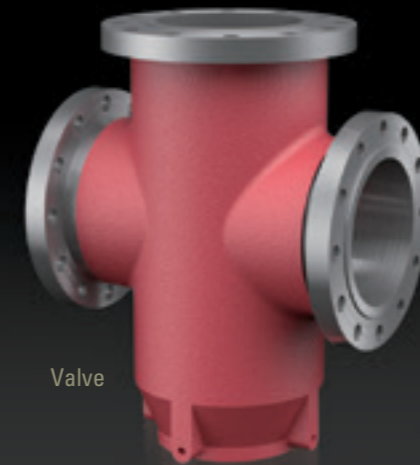

Valve



Gear box



## Wide machining range

Axis travels (X, Y, Z): 1900 × 1600 × 1700 mm



Maximum workpiece size when pallet is changed (diameter × height)

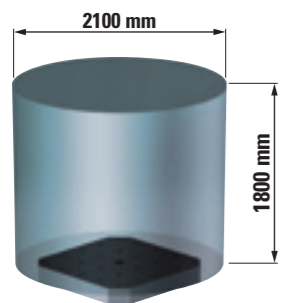

Maximum payload (evenly distributed)  
3000 kg (optional specification: 5000 kg)

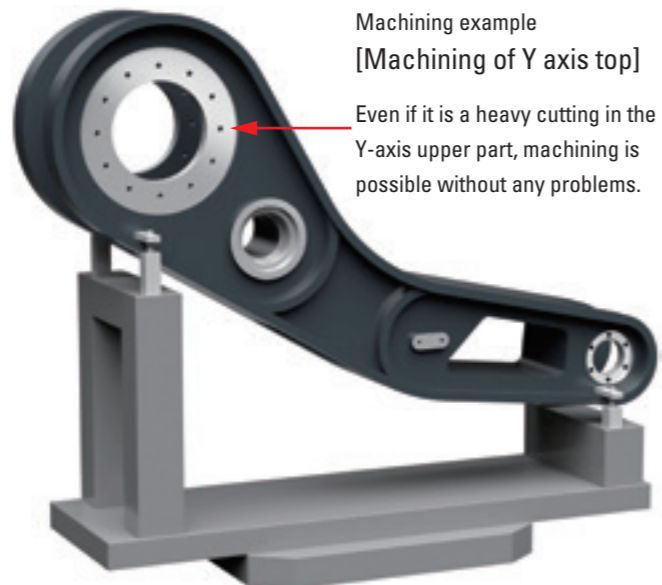

Machining example  
[Machining of Y axis top]

Even if it is a heavy cutting in the Y-axis upper part, machining is possible without any problems.



## Machine structure

Rapid traverse (X, Y, Z): 54 m/min

### Advanced axis cooling system

Heat generation in the axes during high speed machining can affect accuracy and performance of the machine. The a120nx machine has the cooling technology of ball screw core and ball screw support bearing. Cooling oil is maintained as per the bed casting temperature and circulated through to the ball screws and end support bearings.

### Roller linear guides

Cylindrical roller guides are used in the X-, Y- and Z-axis. Rollers provide line contact area, which enhances rigidity and load capacities of the machines.

### Stepped column

The two X-axis guides under the column are at different heights. This stepped design supports the machine to move at high speed and high acceleration mode by reducing the weight of column without compromising rigidity of the machine in Z-axis direction.

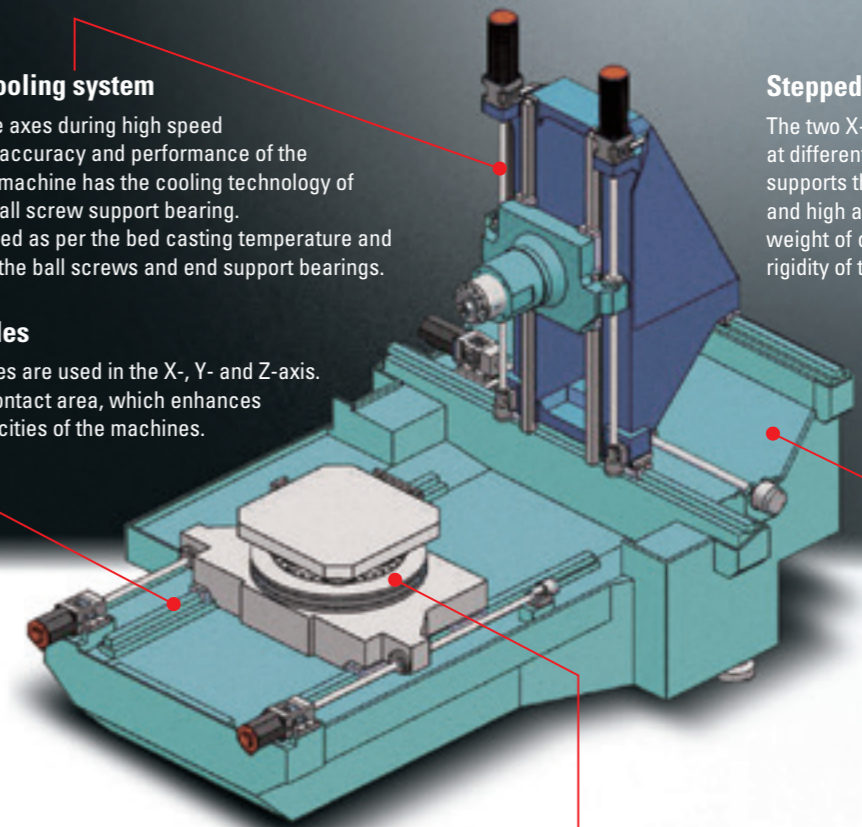

### Tolerances measured at Makino's assembly plant

Positioning accuracy  $\pm 2.5 \mu\text{m}$  (with scale feedback)  
 $\pm 3.0 \mu\text{m}$  (without scale feedback)

Repeatability  $\pm 1.0 \mu\text{m}$  (with scale feedback)  
 $\pm 1.5 \mu\text{m}$  (without scale feedback)

\* Scale feedback: optional specification \* Measured according to JIS standard/ISO standard

### Pallet clamping system

Pallet can be precisely located four taper-cones. Each taper cone supports and clamps pallet in a strongly grasping. High cutting performance is realized even at the upper point on Y-axis.

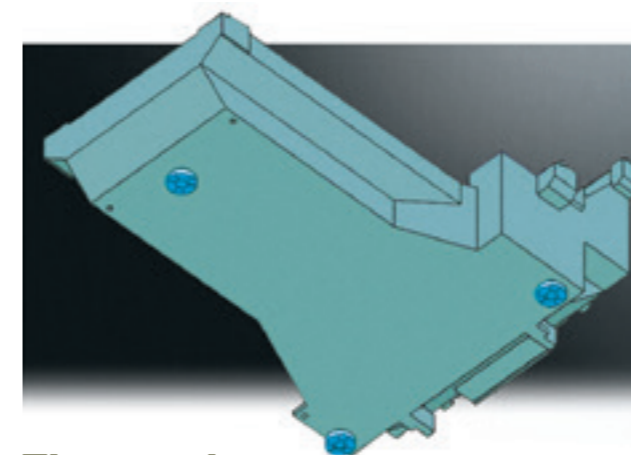

### Three-point support

a120nx boasts the world's largest class of strokes as a machine of a three-point support.

The advantages of three-point support

- A machine is hard to be affected by aged deterioration of foundation.
- Periodic level maintenance is not required.
- Reduction of foundation cost

### Inertia Active Control (patented)

Pallet inertia is automatically measured. Then B-axis acceleration/deceleration are optimized.

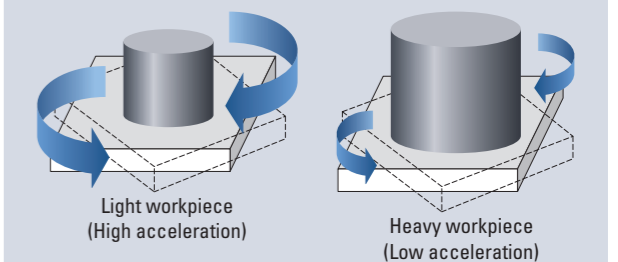



**High torque spindle 8000 min<sup>-1</sup>, 1202 N·m** Acceleration time (0→8000 min<sup>-1</sup>) **3.4 sec - stop 3 sec**



The spindle that is the most suitable for machining which requires the very large torque such as large diameter boring, large diameter drilling, and large diameter face mill machining, etc. as cast iron and stainless steel as material.

## Professional 6

Even in machining with high-speed and high-acceleration, machining surface quality and shape accuracy can be kept, further, shorten the machine time.



(Photo: a61nx)

### GI milling

Tolerance amount at the corner section of the tool path can be defined. Accordingly, the corner section movement can be made smoothly by reducing deceleration width of federate.

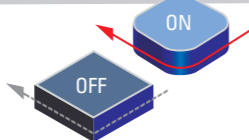
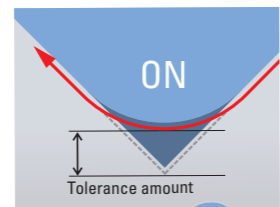

### GI drilling

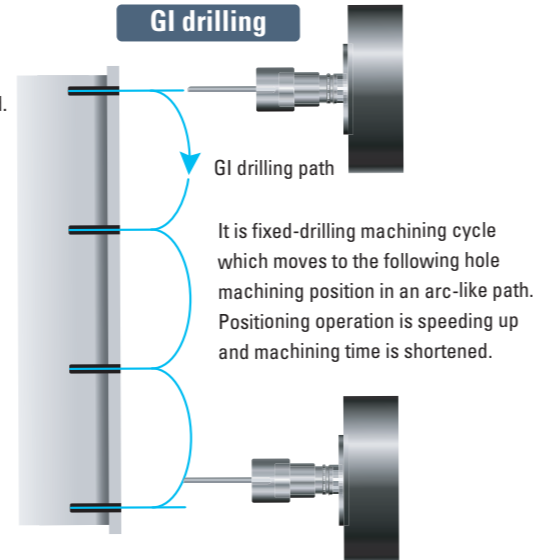

**ATC** Automatic tool changer is possible to use the tools suitable for a wide range of machining area.

**Tool storage capacity 204 tools (Matrix type)**

**Maximum tool diameter : 356 mm**

**Maximum tool length : 900 mm**

**Maximum tool weight : 35 kg**

**Maximum tool moment : 50 N·m**

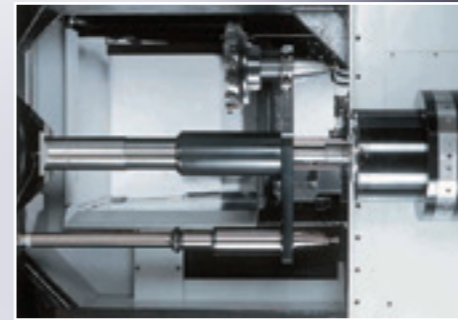

### Tool loading station (TLS)

A maximum of 35 kg tool can be set efficiently and safely.

### Long tool machining

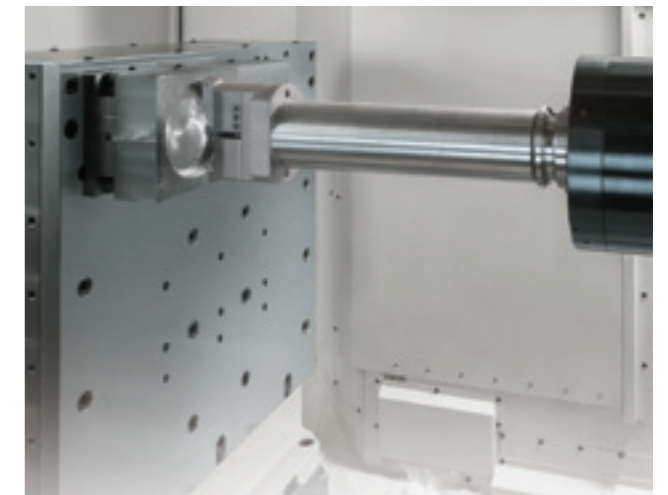

Machining example

**[150 mm dia. boring rough machining]**

Workpiece material : FCD450

Machining position : 1400 mm from table top surface

Radial depth of cutting : 15 mm



## Pallet changer

Equipped as standard specification. It enables setup of during machining and contribute to production improvement.

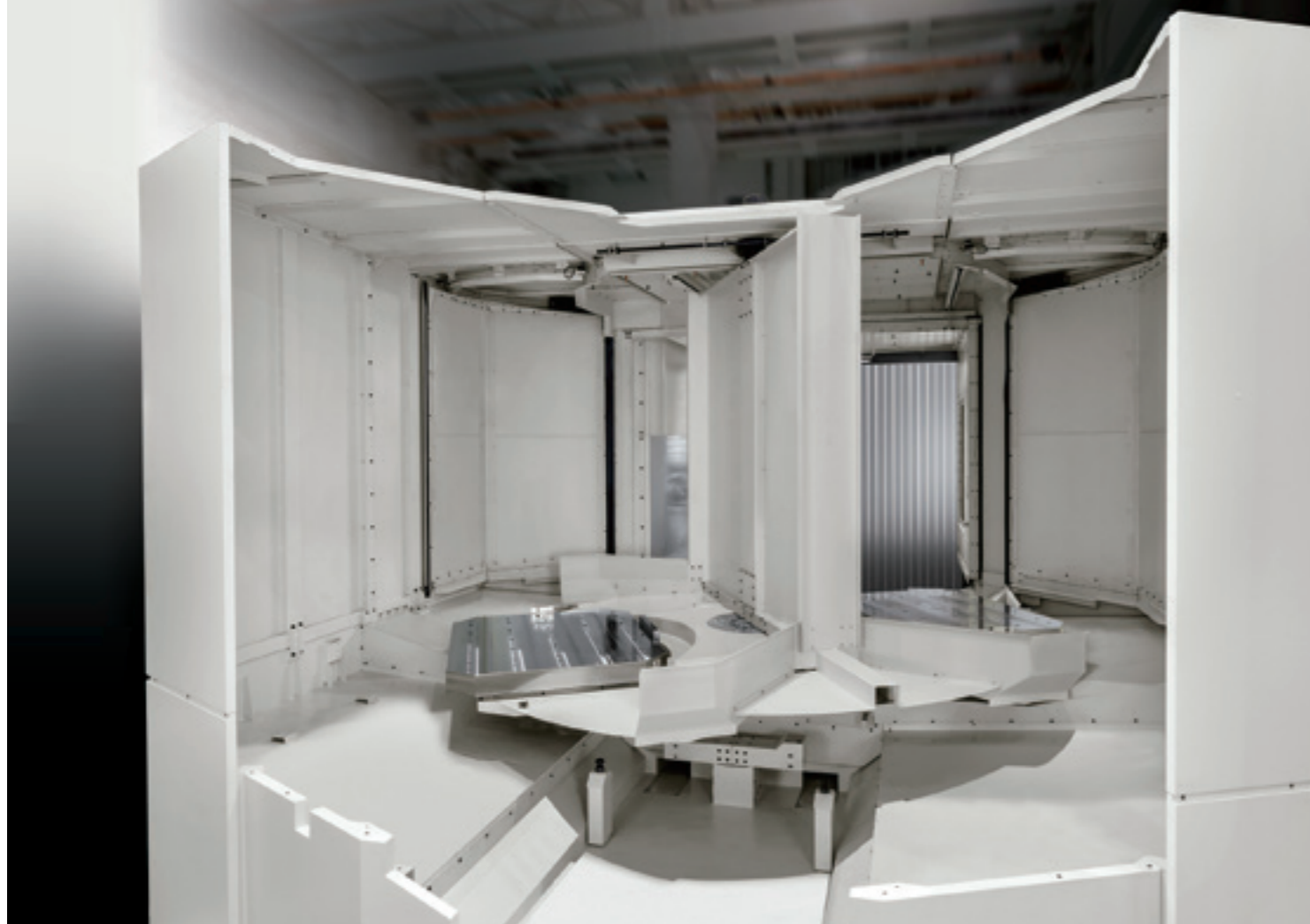

## Chip evacuation system

Coolant from the spindle head and ceiling of the guard flush the chips into the center trough directly under the table. The conveyor inside the machine discharges chips surely outside the machine.

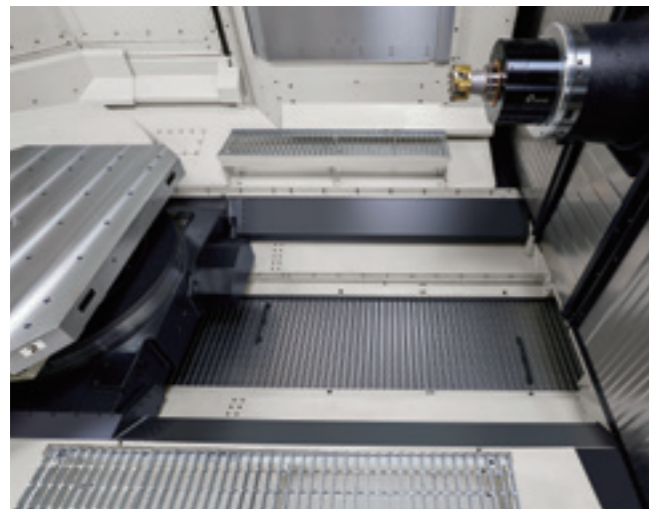

### Secondary filtration unit cyclone type is provided as standard equipment

- ◎ Completely separates fine sludge from coolant that could not be collected by a conveyor.
- ◎ Always maintains filtration accuracy 20 $\mu$ m.

## Easy operation

The design which considered operator's usability to the maximum.

### Pallet loading station (PLS)

Opening the large door at the PLS provides easy access to the crane when loading fixtures and workpiece without any obstruction.



### Excellent spindle accessibility

The L-shape operator door provides convenient spindle and tool access easily. This provides ideal visibility to the workpiece, tools and fixtures.

More efficient work becomes possible by machining chamber step (optional specification).



### Easy maintenance

Units that require daily inspection are placed together on the side panels of the machine. An automatic grease supply unit is equipped as standard equipment.



# Automation

The automation system module MMC of Makino with high extensibility and abundant experience. It is possible to start with one machine at first and gradually expand the scale.

**Module MMC Floor plan example**

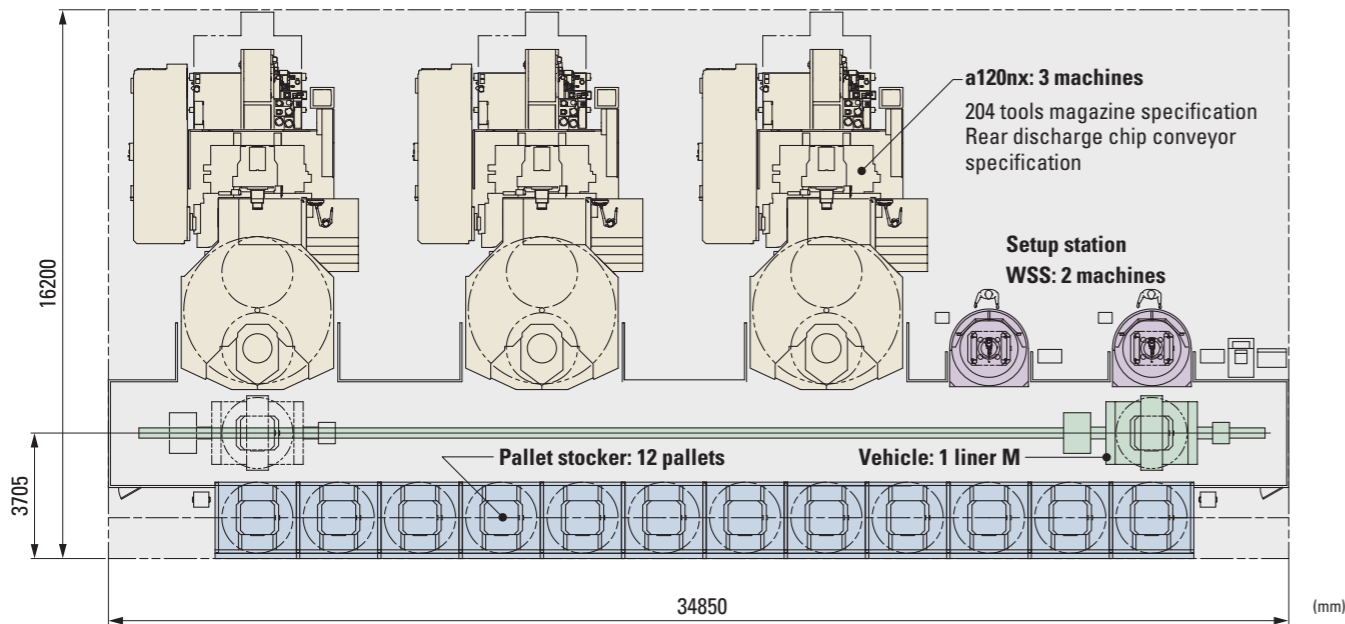

Front view / Floor plan

Detailed diagram of pallet

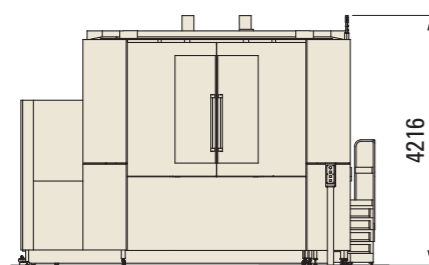
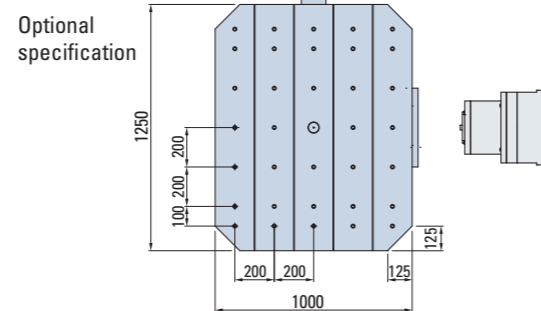
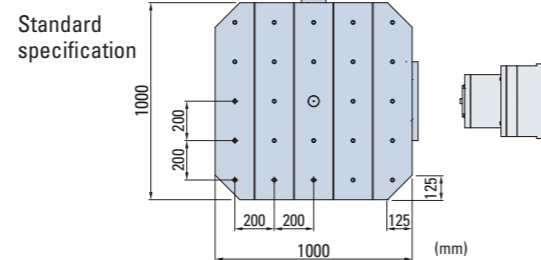
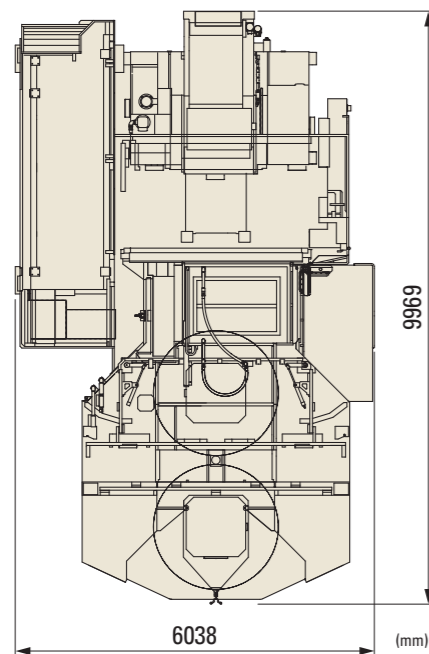

**External step**

\* External step as shown in the figure is required at a customer side.

\* The space for the movable parts and maintenance in addition to the space for the machine main body are required. For the details, please refer to the specification.

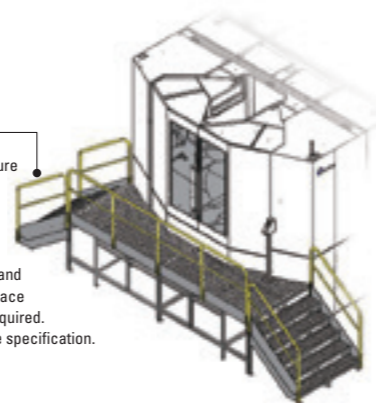

## Specifications

Axis travels	X × Y × Z	1900 × 1600 × 1700 mm
	Distance to spindle center from pallet surface	100 - 1700 mm
	Distance to spindle end line from pallet center	150 - 1850 mm
Pallet	Size	1000 × 1000 mm
	Maximum work size (diameter × height)	2100 × 1800 mm
	Maximum payload (evenly distributed)	3000 kg (optional specification : 5000 kg)
	Surface configuration	24 × M16 tapped hole
	Minimum index angle	0.0001°
Spindle	Index time (90 / 180°)	2.5 / 4.0 seconds
	Speed	20 - 8000 min <sup>-1</sup>
	Interface	7/24 taper #50
	Bearing diameter (inner / outer)	120 / 180 mm
Feedrates	Motor power (25%ED / Cont.)	55 / 37 kW
	Torque (25%ED / Cont.)	1202 / 553 N·m
	Rapid traverse	54000 mm/min
Automatic tool changer	Cutting feedrate	1 - 54000 mm/min
	Number of tool storage capacity	204 tools
	Maximum tool diameter (without condition / with condition)	102 / 356 mm
	Maximum tool length	900 mm
Machine size (standard specification)	Maximum tool weight	35 kg (moment 50 N·m)
	Size (Width × Depth × Height)	6038 × 9969 × 4216 mm
Floor space	Weight (including NC unit)	44500 kg
	Width × Depth	7500 × 12150 mm

## Standard specifications

- 8000 min<sup>-1</sup> spindle
- Spindle temperature controller
- Rotary table
- Pallet changer
- Pallet clamp confirmation function
- Pallet with tapped hole 1000 × 1000 mm
- 204 tools magazine
- Automatic grease supply unit
- Nozzle coolant
- Overhead shower coolant system
- Through spindle coolant (1.5 MPa) and air
- Terrace washing coolant
- Lift up chip conveyor
- Secondary filtration unit for through spindle coolant
- Operator door lock (operation mode)
- Splash guard lighting device
- Pallet changer safety guard
- Signal light 3- layer
- Automatic power-off
- Rigid tap
- Portable manual plus generator with tool position display (with handle enable button)
- ECO mode functions
- Professional 6

## Optional specifications (◎) / Optional equipment (☆)

- ◎ HSK-A100 spindle
- ◎ Pallet 1000 × 1250 mm
- ◎ T slots pallet specification
- ☆ Machining chamber internal step
- ☆ Additional pallet
- ◎ Maximum payload 5000 kg specification
- ◎ Scale feedback (0.05 μm)
- ◎ Through spindle coolant (3 MPa) and air
- ◎ Through spindle coolant (7 MPa) and air
- ☆ Rotation wiper for splash guard window
- ◎ Lift-up chip conveyor (rear discharge double layer)
- ◎ Lift-up chip conveyor (rear discharge, for cast iron)
- ☆ Coolant temperature controller (with heater)
- ☆ Oil skimmer
- ☆ Workpiece washing gun
- ☆ Air blower
- ☆ Mist collector
- ☆ Air dryer
- ☆ Broken tool sensor on ATC side
- ☆ Automatic tool length measuring device
- ☆ Automatic workpiece measuring device (radio type)
- ☆ Super G1.5 control
- ☆ I/O interface for measurement
- ☆ MTConnect interface
- ☆ OPC UA interface
- ◎ Customer specified machine color